

Principles of Jet Engine Operation

The main function of any aeroplane propulsion system is to provide a force to overcome the aircraft drag, this force is called thrust. Both propeller driven aircraft and jet engines derive their thrust from accelerating a stream of air - the main difference between the two is the amount of air accelerated. A propeller accelerates a large volume of air by a small amount, whereas a jet engine accelerates a small volume of air by a large amount.

This can be understood by Newton's 2nd law of motion which is summarized by the equation $\mathbf{F} = \mathbf{ma}$ (*force = mass x acceleration*). Basically the force or thrust (F) is created by accelerating the mass of air (m) by the acceleration (a).



A propeller accelerates a large volume of air by a small amount



A jet engine accelerates a small volume of air by a large amount

Given that thrust is proportional to airflow rate and that engines must be designed to give large thrust per unit engine size, it follows that the jet engine designer will generally attempt to maximize the airflow per unit size of the engine. This means maximizing the speed at which the air can enter the engine, and the fraction of the inlet area that can be devoted to airflow. Gas turbine engines are generally far superior to piston engines in these respects, therefore piston-type jet engines have not been developed.

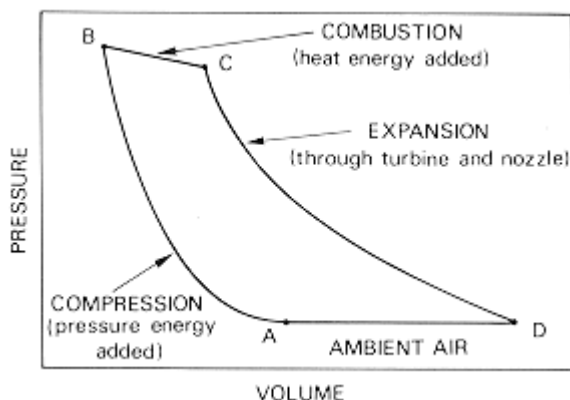

The operation cycle of a gas turbine

The gas turbine engine is essentially a heat engine using air as a working fluid to provide thrust. To achieve this, the air passing through the engine has to be accelerated; this means that the velocity or kinetic energy of the air must be increased. First, the pressure energy is raised, followed by the addition of heat energy, before final conversion back to kinetic energy in the form of a high velocity jet. The basic mechanical arrangement of a gas turbine is relatively simple. It consists of only four parts:

1. The *compressor* which is used to increase the pressure (and temperature) of the inlet air.
2. One or a number of *combustion chambers* in which fuel is injected into the high pressure air as a fine spray, and burned, thereby heating the air. The pressure remains (nearly) constant during combustion, but as the temperature rises, each kilogram of hot air needs to occupy a larger volume than it did when cold and therefore expands through the turbine.

3. The *turbine* which converts some of this temperature rise to rotational energy. This energy is used to drive the compressor.
4. The exhaust *nozzle* which accelerates the air using the remainder of the energy added in the combustor, producing a high velocity jet exhaust.

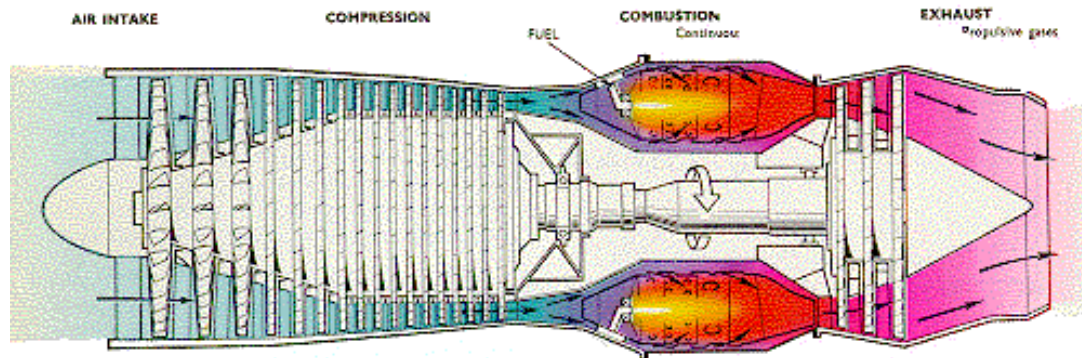

A schematic of a gas-turbine engine (turbojet)

This generalization, however, does not extend to the detailed design of the engine components, where account has to be taken of the high operating temperatures of the combustion chambers and turbine; the effects of varying flows across the compressor and turbine blades; and the design of the exhaust system through which the gases are ejected to form the propulsive jet.

The Compressor

In the gas turbine engine, compression of the air is effected by one of two basic types of compressor, one giving centrifugal flow and the other axial flow. Both types are driven by the engine turbine and are usually coupled direct to the turbine shaft.



A centrifugal impeller

The centrifugal flow compressor employs an impeller to accelerate the air and a diffuser to produce the required pressure rise. Flow exits a centrifugal compressor radially (at 90° to the flight direction) and it must therefore be redirected back towards the combustion chamber, resulting in a drop in efficiency.

The axial flow compressor employs alternate rows of rotating (rotor) blades, to accelerate the air, and stationary (stator) vanes, to diffuse the air, until the required pressure rise is obtained.

The pressure rise that may be obtained in a single stage of an axial compressor is far less than the pressure rise achievable in a single centrifugal stage. This means that for the same pressure rise, an axial compressor needs many stages, but a centrifugal compressor may need only one or two.

An engine design using a centrifugal compressor will generally have a larger frontal area than one using an axial compressor. This is partly a consequence of the design of a centrifugal impeller, and partly a result of the need for the diffuser to redirect the flow back towards the combustion chamber. As the axial compressor needs more stages than a centrifugal compressor for the equivalent pressure rise, an engine designed with an axial compressor will be longer and thinner than one designed using a centrifugal compressor. This, plus the ability to increase the overall pressure ratio in an axial compressor by the addition of extra stages, has led to the use of axial compressors in most engine designs, however, the centrifugal compressor is still favoured for smaller engines where its simplicity, ruggedness and ease of manufacture outweigh any other disadvantages.



An axial flow compressor (stators omitted for clarity). This is the high pressure compressor from a General Electric F404 engine.

Combustion Chamber

The combustion chamber has the difficult task of burning large quantities of fuel, supplied through fuel spray nozzles, with extensive volumes of air, supplied by the compressor, and releasing the resulting heat in such a manner that the air is expanded and accelerated to give a smooth stream of uniformly heated gas. This task must be accomplished with the minimum loss in pressure and with the maximum heat release within the limited space available.

The amount of fuel added to the air will depend upon the temperature rise required. However, the maximum temperature is limited to within the range of 850 to 1700 °C by the materials from which the turbine blades and nozzles are made. The air has already been heated to between 200 and 550 °C by the work done in the compressor, giving a temperature rise requirement of 650 to 1150 °C from the combustion process. Since the gas temperature determines the engine thrust, the combustion chamber must be capable of maintaining stable and efficient combustion over a wide range of engine operating conditions.

The temperature of the gas after combustion is about 1800 to 2000 °C, which is far too hot for entry to the nozzle guide vanes of the turbine. The air not used for combustion, which amounts to about 60 percent of the total airflow, is therefore introduced progressively into the flame tube. Approximately one third of this gas is used to lower the temperature inside the combustor; the remainder is used for cooling the walls of the flame tube. There are three main types of combustion chamber in use for gas turbine engines. These are the multiple chamber, the can-annular chamber and the annular chamber.

- **Multiple chamber**

This type of combustion chamber is used on centrifugal compressor engines and the earlier types of axial flow compressor engines. It is a direct development of the early type of Whittle engine combustion chamber. Chambers are disposed radially around

the engine and compressor delivery air is directed by ducts into the individual chambers. Each chamber has an inner flame tube around which there is an air casing. The separate flame tubes are all interconnected. This allows each tube to operate at the same pressure and also allows combustion to propagate around the flame tubes during engine starting.

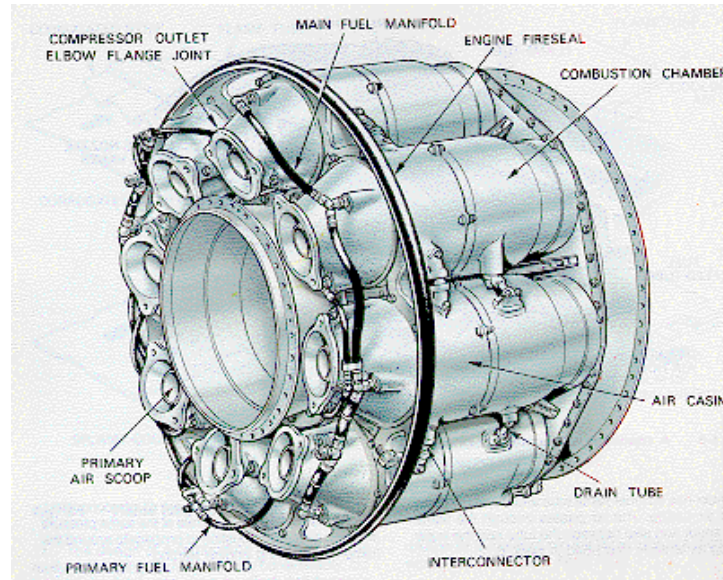

A multiple combustion chamber

- **Can-annular chamber**

This type of combustion chamber bridges the evolutionary gap between multiple and annular types. A number of flame tubes are fitted inside a common air casing. The airflow is similar to that already described. This arrangement combines the ease of overhaul and testing of the multiple system with the compactness of the annular system.

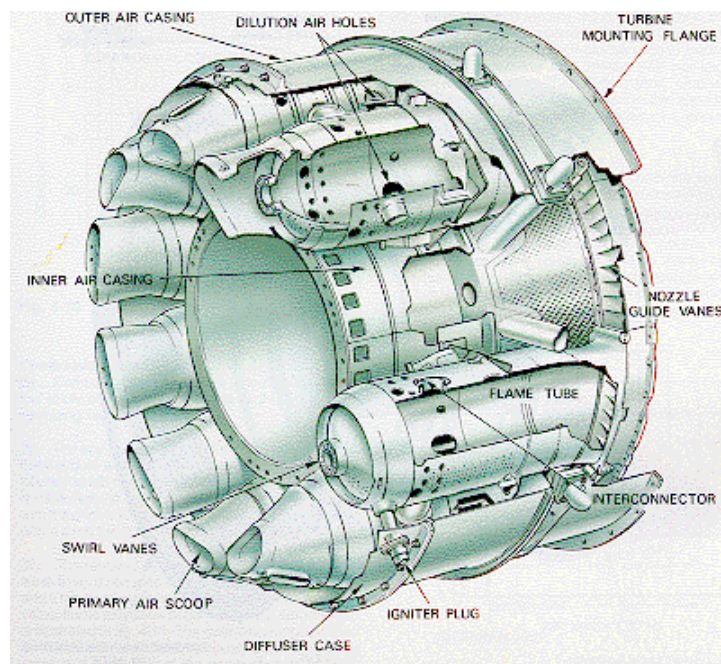

A can-annular combustion chamber

- **Annular chamber**

This type of combustion chamber consists of a single flame tube, completely annular in form, which is contained in an inner and outer casing. The main advantage of the annular combustion chamber is that for the same power output, the length of the chamber is only 75 per cent of that of a can-annular system of the same diameter, resulting in a considerable saving in weight and cost. Another advantage is the elimination of combustion propagation problems from chamber to chamber.

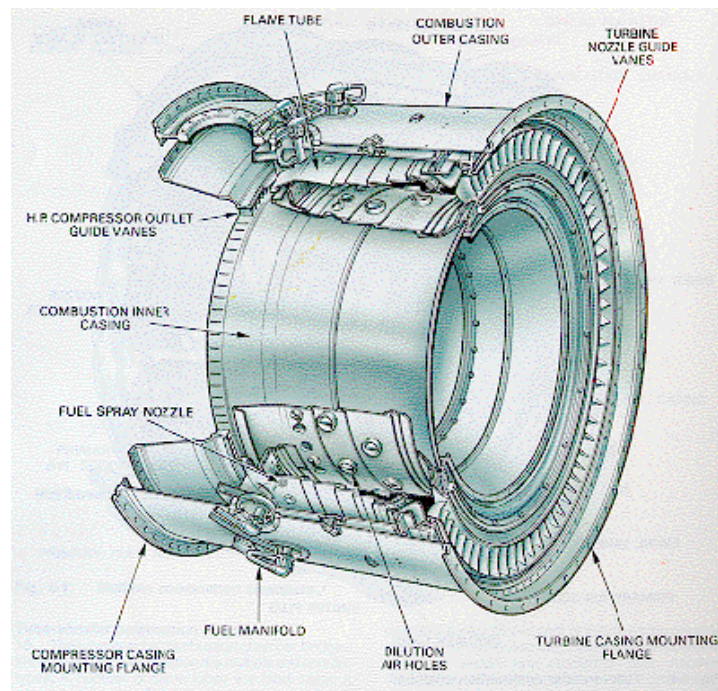

An annular combustion chamber

Turbine

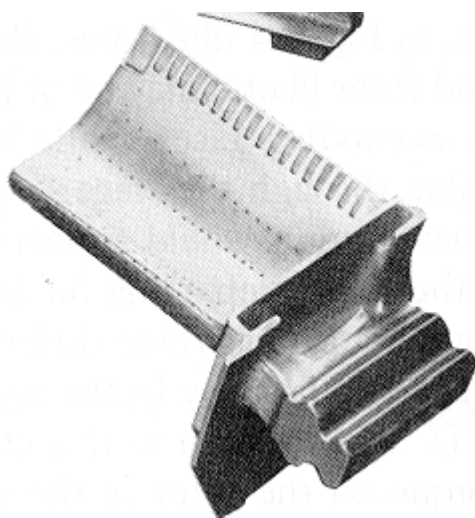

A turbine blade with cooling holes

The turbine has the task of providing power to drive the compressor and accessories. It does this by extracting energy from the hot gases released from the combustion system and expanding them to a lower pressure and temperature. The continuous flow of gas to which the turbine is exposed may enter the turbine at a temperature between 850 and 1700 °C which is far above the melting point of current materials technology.

To produce the driving torque, the turbine may consist of several stages, each employing one row of stationary guide vanes, and one row of moving blades. The number of stages depends on the relationship between the power required from the gas flow, the rotational speed at which it must be produced, and the

diameter of turbine permitted. The design of the nozzle guide vanes and turbine blade passages is broadly based on aerodynamic considerations, and to obtain optimum efficiency, compatible with compressor and combustor design, the nozzle guide vanes and turbine blades are of a basic aerofoil shape.

The desire to produce a high engine efficiency demands a high turbine inlet temperature, but this causes problems as the turbine blades would be required to perform and survive long operating periods at temperatures above their melting point. These blades, while glowing red-hot, must be strong enough to carry the centrifugal loads due to rotation at high speed.

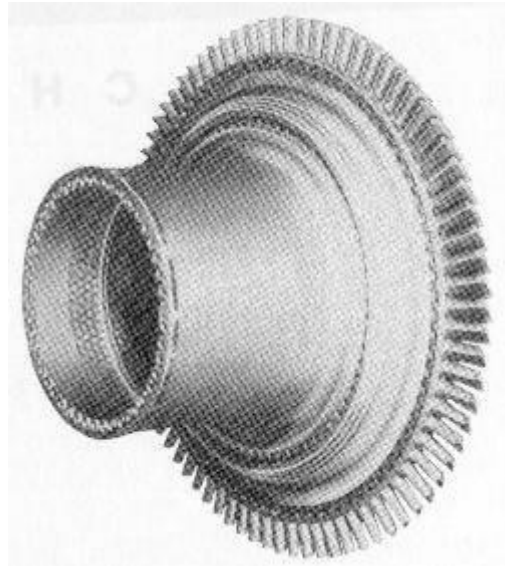

A high-pressure turbine stage from a CFM56 turbofan engine

To operate under these conditions, cool air is forced out of many small holes in the blade. This air remains close to the blade, preventing it from melting, but not detracting significantly from the engine's overall performance. Nickel alloys are used to construct the turbine blades and the nozzle guide vanes because these materials demonstrate good properties at high temperatures.

Exhaust Nozzle

Gas turbine engines for aircraft have an exhaust system which passes the turbine discharge gases to atmosphere at a velocity in the required direction, to provide the necessary thrust. The design of the exhaust system, therefore, exerts a considerable influence on the performance of the engine. The cross sectional areas of the jet pipe and propelling or outlet nozzle affect turbine entry temperature, the mass flow rate, and the velocity and pressure of the exhaust jet.

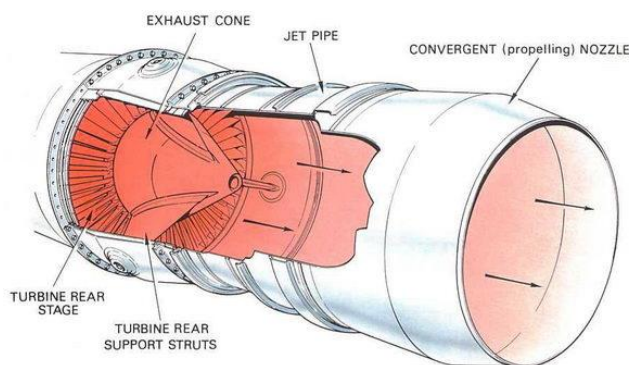

A basic exhaust system

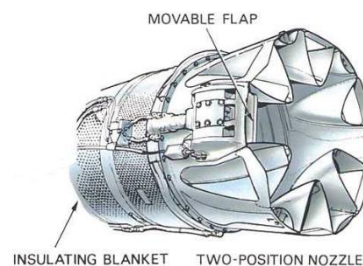

A more complex exhaust system with two position nozzle and noise suppresser

A basic exhaust system function is to form the correct outlet area and to prevent heat conduction to the rest of the aircraft. The use of a thrust reverser (to help slow the aircraft on landing), a noise suppresser (to quieten the noisy exhaust jet) or a variable area outlet (to improve the efficiency of the engine over a wider range of operating conditions) produces a more complex exhaust system.

Afterburners

In addition to the basic components of a gas turbine engine, one other process is occasionally employed to increase the thrust of a given engine. Afterburning (or reheat) is a method of augmenting the basic thrust of an engine to improve the aircraft take-off, climb and (for military aircraft) combat performance.

Afterburning consists of the introduction and burning of raw fuel between the engine turbine and the jet pipe propelling nozzle, utilizing the unburned oxygen in the exhaust gas to support combustion. The resultant increase in the temperature of the exhaust gas increases the velocity of the jet leaving the propelling nozzle and therefore increases the engine thrust. This increased thrust could be obtained by the use of a larger engine, but this would increase the weight, frontal area and overall fuel consumption. Afterburning provides the best method of thrust augmentation for short periods.

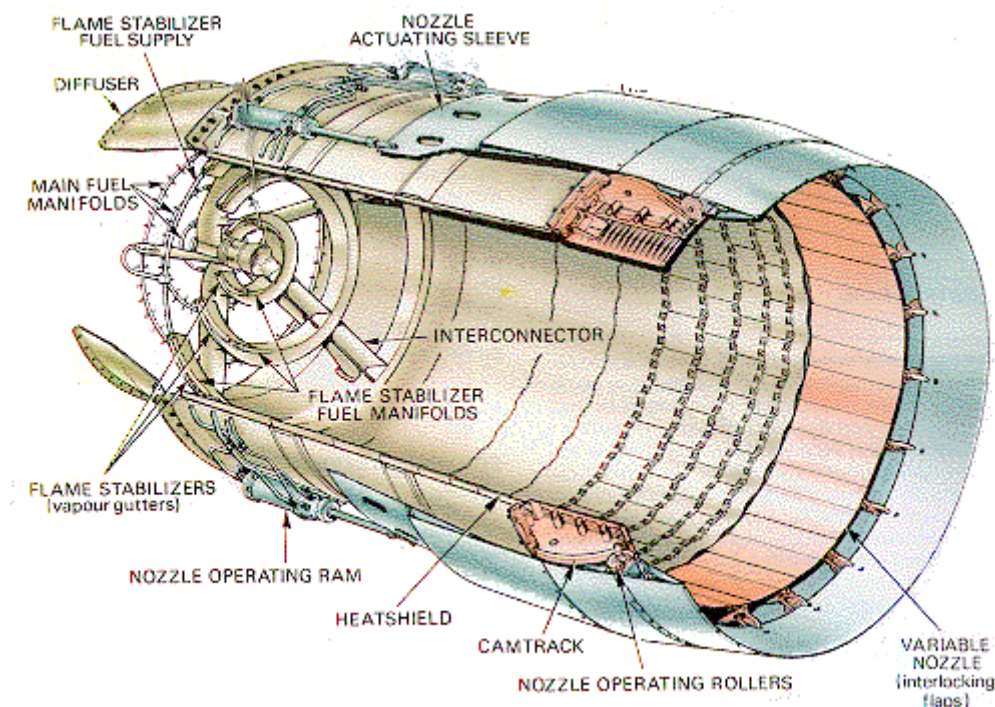

Typical afterburning jet pipe equipment

Afterburners are very inefficient as they require a disproportionate increase in fuel consumption for the extra thrust they produce. Afterburning is used in cases where fuel efficiency is not critical, such as when aircraft take off from short runways, and in combat, where a rapid increase in speed may occasionally be required.

Working Principle of Turbofan Engine

Turbofan engine basically is combination of turbojet engine and propeller. It is gas turbine, compression ignited jet engine. Turbofan engine works on principle of open cycle (Bryton cycle, joule cycle). In this engine a large fan covered by duct mounted on a shaft ahead of compressor. Turbine drives both fans and the compressor through shaft.

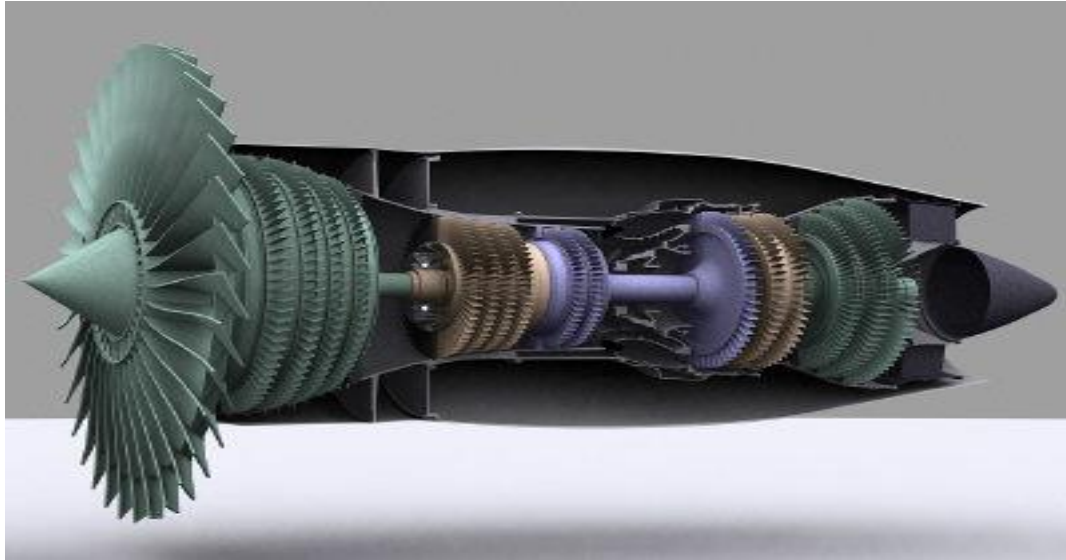

The working principle of turbofan engine is very similar with the jet engine. Only difference between jet engine and turbofan engine is that turbofan engine includes fan in front section where air enters.

- Fan
- Compressor
- Combustion Chamber(cc)
- Turbine
- Nozzle

FAN:-

Duct fan suck a large mass of air or it accelerate air into the inner and outer shred. This unburden air mixed with exhaust downstream of nozzle. Net thrust of turbofan engine is produced by combination of thrust produced by nozzle exhaust and fan. Therefore efficiency of turbofan engine is more than turbojet engine.

COMPRESSOR:-

Some of Air sucked by fan and air entering directly into engine is compressed by compressor. Here velocity of air is decreased and pressure is increased with the help of stator (stationary part of compressor) and rotors (rotating part of compressor). Highly pressurized and highly temperature air is obtained after compressor. Here temperature of gas is increased as per ideal gas equation ($pV = nRT$). That is, pressure is directly proportional to temperature. As pressure is increased temperature also increased.

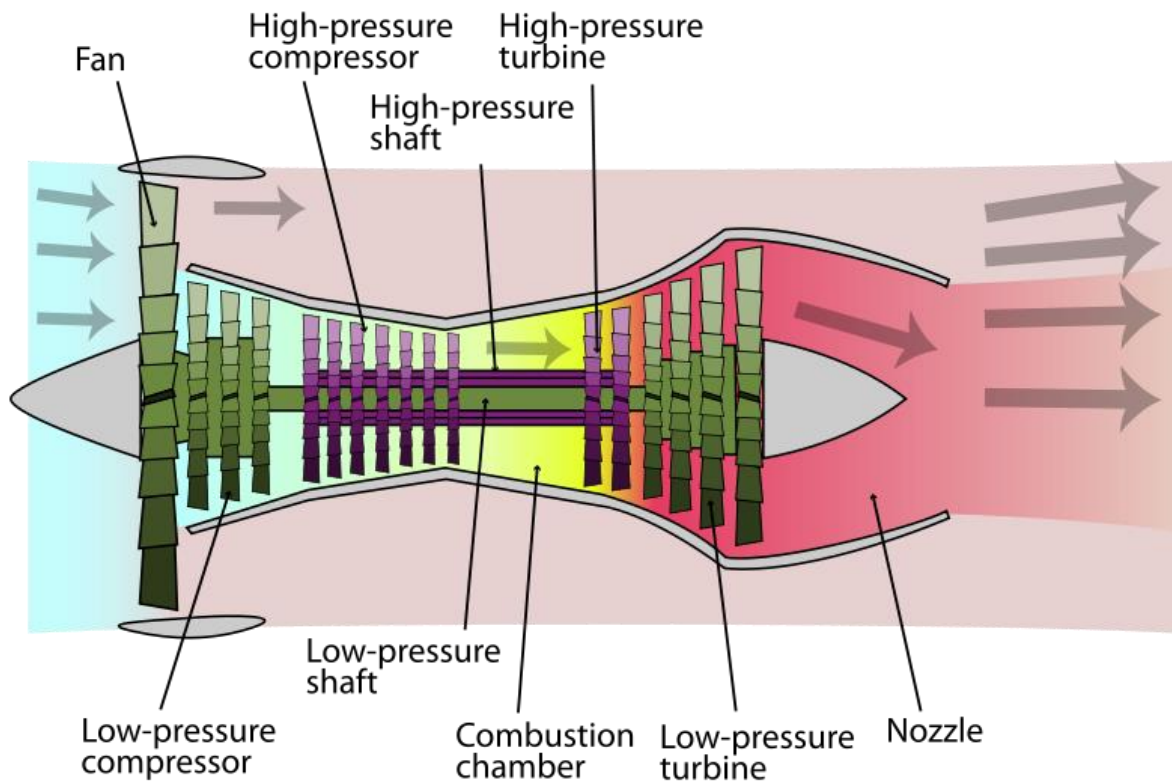

COMBUSTION CHAMBER:-

Highly pressurized and highly temperature (more than ignition temperature) air enters into combustion chamber. Here atomized fuel is sprayed into combustion chamber which burned after coming just in contact with hot air. High velocity hot gases are produced here which flows towards turbine. These gases gain high energy by combustion.

TURBINE:-

After combustion chamber hot gases produced flows through turbine. Turbine takes energy from hot gases and starts rotating. It rotate compressor as well as fan with help of shaft. This is an expansion process of gases. Here gases expands and velocity becomes little bit higher.

NOZZLE:-

Hot gases coming from turbine section exhausted out with the help of nozzle with very high speed depending upon types of nozzle. Nozzle used are mainly convergent-divergent nozzle for supersonic speed and convergent nozzle for subsonic speed.